

LINE ARRAY SERIES

**MA-206 D & P
MAW-115D/1K**



Copyright © 2009
All rights reserved

Pol. Ind. Norte - Perpinyà, 25
08226 TERRASSA (Barcelona-SPAIN)
info@master-audio.com
www.master-audio.com

Nov 09
User's manual

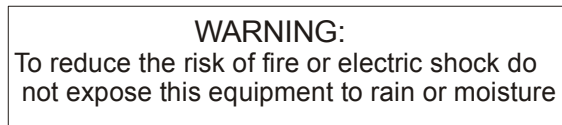

Safety Instructions

1. All the safety and operation instructions should be read before this product is operated.
2. The exclamation point within an equilateral triangle is intended to alert the user of the presence of internal components whose substitution may affect safety.
3. The lightning flash with arrowhead symbol within an equilateral triangle is intended to alert the user of the presence of uninsulated dangerous voltage, that may constitute a risk of electric shock to people.
4. This product should not be exposed to rain or moisture. Do not use it, for example, near a swimming pool, water fountain or any liquid sources.
5. Clean only with a dry cloth.
6. This product should be situated so that its location does not interfere with its proper ventilation.
7. Do not install near heat sources such as radiators or other devices which produce heat.
8. This equipment should be serviced only by qualified service personnel when:
 - A. The power-supply cord or the plug has been damaged; or
 - B. Objects have fallen or liquid has been spilled onto it; or
 - C. This product does not appear to operate normally; or
 - D. This product has been exposed to rain; or
 - E. The chassis is damaged.
9. Unplug this product during lightning storms or when unused for long periods of time.
10. Do not suspend the cabinet from the handles.

1.INTRODUCTION

1.1.General

Amate Electroacústica, s.l. would like to thank you for your confidence in our new **MA** and **MAW Series**, specially designed for Line Array configurations.

The accumulated experience of more than 30 years in the design of acoustic cabinets and amplifiers, together with the application of the most advanced technology and transducers, have allowed this series to become the optimal and ideal solution for a wide range of situations, specially those which require high levels of sound pressure and a control of vertical coverage. Stadiums, theatres, big events, etc... will become the perfect places for its use.

We suggest you carefully read the following instructions in order to obtain the best results in performance.

1.2.What is a line array?

The trend in sound reinforcement has been to increase both the sound pressure level (SPL) and the size of the audience to be covered. This leads to an increase in the number of cabinets and, as a result of this, an increase in the total size and weight.

A line array is a group of independent sound sources which are vertically stacked in order to transform the spherical wavefronts generated by individual sources into a single flat wavefront.

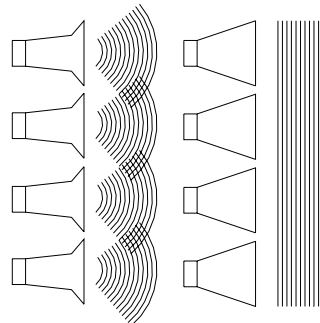

Fig.1. Wavefield interference for different wavefronts.

To carry out effectively arraying individual sound sources the system must follow the acoustic coupling conditions based on the wavelength, the shape of each source, the surface area of each transducer and the relative source separation.

An assembly of individual sound sources arrayed with regular separation between the sources on a plane or curved continuous surface is equivalent to a single sound source having the same dimensions as the total assembly if the following conditions are fulfilled:

1) The step of source separation, defined as the distance between the acoustic centres of the individual sources, is smaller than half the wavelength over the bandwidth of operation.

$$d \leq \lambda/2$$

It is easy to fulfil this first condition for the low and mid frequencies. For example, two 7" loudspeakers that are separated by 17 cm will reproduce a cylindrical wave up to 1015 Hz.

This condition is difficult to be fulfilled for the high frequencies, as their wavelengths are too small to make the adjacent acoustic centres any smaller than $\lambda/2$. Here comes the second "arrayability" criterion.

2) The wavefronts generated by the individual sources are planar and the combined surface area of the sources fills at least 80% of the total target surface area:

$$H_1 \cdot W + H_2 \cdot W + \dots + H_n \cdot W \geq 0.8 \cdot H \cdot W$$

This is achieved by using waveguides, which are coupled to the compression drivers output. We achieve flat wavefronts with a constant phase. By vertically assembling these waveguides we fulfil the second criterion of line array construction.

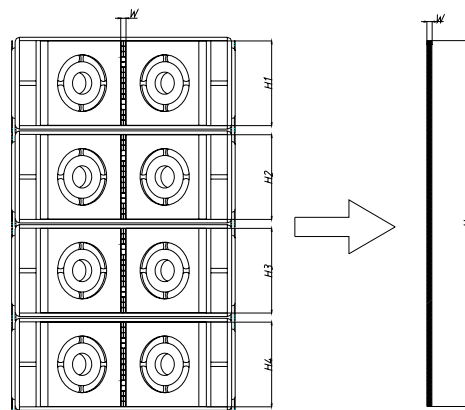

Fig.2. Second criterion of "arrayability"

3) The deviation from a flat wavefront must be less than $\lambda/4$ at the highest operating frequency (this corresponds to less than 5 mm curvature at 16kHz).

This third condition can be explained through our property waveguide. Thanks to some complex mathematical calculations we have obtained an aluminium component which is able to adapt the circular section of the compression driver to a rectangular section, getting on-phase waves at the end of the guide. This flat wavefront is ideal for vertical configurations.

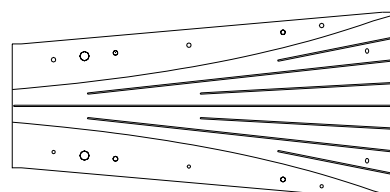

Fig.3. High frequency waveguide

Sound engineers use line arrays to obtain narrow directivities on the vertical plane. For configurations with many cabinets (big height) and at high frequencies it is not unusual to achieve narrow angles- in some cases they may be grade fractions. This can be useful in venues where both a high sound pressure level and long throw are required; nevertheless, this means less coverage of the audience area.

It is sometimes useful to achieve an asymmetrical coverage pattern on the vertical plane, which can be obtained by aiming some of the cabinets through their hinging points. We are now ready to define the last two criteria of "arrayability".

4) For curved arrays, the tilt angles should vary in inverse proportion to the listener distance (this is geometrically equivalent to shaping variable curvature arrays to provide equal spacing of individual element impact zones).

5) There are limits given the vertical size of each cabinet and their relative tilt angles. In our case the maximum angle between cabinets is 8° .

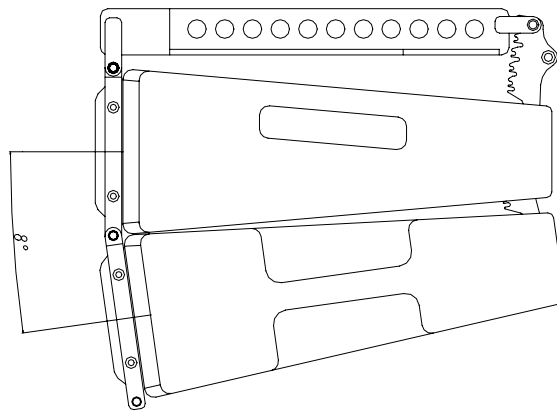

Fig.4. Tilt angle between cabinets (8° maximum)

1.3.Fresnel Region (Near Field) and Fraunhofer Region (Far Field)

If our system is able to fulfil the previous conditions it will produce cylindrical waves to a maximum frequency. The wave will be flat up to a certain distance where it will start to become spherical (depending on the frequency and the size of the array).

The limit distance between the zone of cylindrical waves (Fresnel) and spherical waves (Fraunhofer) can be calculated through the following formula

$$d_c = \frac{3}{2} H^2 f \sqrt{1 - \left(\frac{1}{3Hf} \right)^2}$$

where

d_c = limit distance between near field and far field (in metres)

H = height of the array (in metres)

f= frequency (in kHz)

In the near field region (Fresnel), the wavefront is cylindrical and waves only expand on the horizontal plane (90° in **MA-206**). The height of the wavefront is, in this case, the total height of the array.

In the far field region (Fraunhofer), the wavefront is spherical and expands both on the horizontal and vertical planes. The horizontal coverage is 90° and the vertical coverage is defined by the frequency and the height of the array.

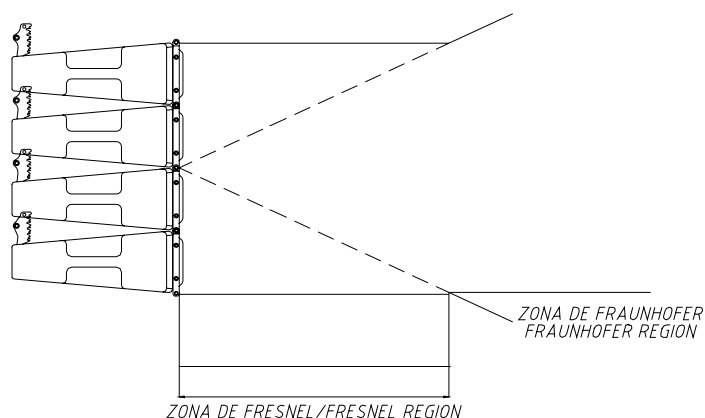

Fig.5. Limits of Fresnel-Fraunhofer Regions

We can create a chart with some of the basic configurations and their performance regarding wave propagation.

Freq (Hz)	4x MA206 d _c (m)	8x MA206 d _c (m)	12x MA206 d _c (m)	16x MA206 d _c (m)
100	Spherical	Spherical	Spherical	Spherical
125	Spherical	Spherical	Spherical	0.72
250	Spherical	0.36	1.48	2.95
500	0.18	1.47	3.54	6.43
1k	0.74	3.21	7.34	13.13
2k	1.6	6.56	14.82	26.33
4k	3.28	13.2	29.7	52.83
8k	6.6	26.4	59.34	105.7
10k	8.25	33	74.31	132.12

Fig.6. d_c Calculation

A 12-cabinet array has a near field extending to 15 metres at 2kHz. Beyond this distance the wavefront will be spherical.

In the first zone (Fresnel), sound pressure loss is of 3 dB per doubling of distance, whereas in the second zone (Fraunhofer) the loss is 6 dB. In long throw and high SPL configurations it is very important to produce cylindrical waves.

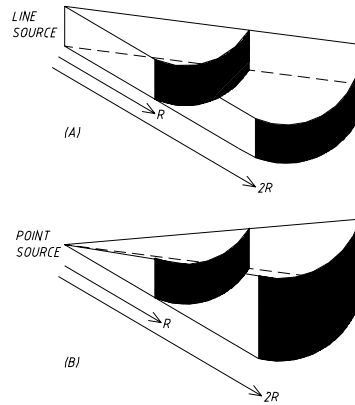

Fig.7. Cylindrical wave (A) vs Spherical wave (B)
 (A) : -3 dB / doubling of distance
 (B) : -6 dB / doubling of distance

2. MA-206 SYSTEM DESCRIPTION

Amate Electroacústica offers the basic set of the **MA-206** System which includes:

- 3 units of the **MA-206/P**
- 1 unit of the **MA-206/D**

This last model is the main unit and includes all the necessary electronics to feed three **MA-206/P** units.

Both models include the same electroacoustic components. They are 2-way units that use two 6.5" for the low-mid frequencies and one 1" compression drivers (44mm voice coil) coupled to property waveguides for the high frequencies. We also introduce a low frequency reinforcement cabinet called **MAW-115** in its active with DSP version (**MAW-115/D**).

2.1. Front design

The **MA-206** shape is "trapezoidal-flat". The "baffles" are flat-shaped and the cabinet has a trap angle of $2 \times 5^\circ$.

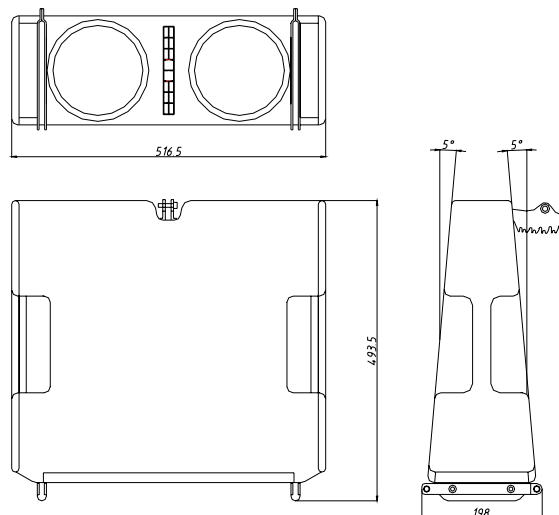

Fig.8. Dimensions of **MA-206**

2.2. 6.5" Neodymium Woofers

The low-mid way includes two 6.5" Neodymium woofers, with 1.5" aluminium voice coil

2.3. 1" Compression drivers with waveguide

The high frequency way includes one 1" compression drivers coupled to planar waveguides. Thanks to their Pure Titanium 44mm diaphragm we achieve an extremely good and clear sound, better than any other option.

The accurate design of our waveguide transforms the spherical waves produced by the driver into planar waves, while transversal stationary waves are also avoided within the audio field (up to 20kHz).

2.4.Finish

In its continuous research into offering the best product at all levels, the **MA-206** has been made of vibration and moisture-resistant birch plywood. All cutting and milling work, as well as drilling operations, has been developed by computerized numeric control machinery (CNC) which allows us to assure perfect and accurate assembly.

The black finish, which uses totally ecological water-based acrylic resin paint, provides an excellent external protection.

We also include a 1.5mm steel Front grille with 5mm acoustically transparent foam.

Each unit incorporates rigging for safe, easy and quick flying or stacking.

2.5. MA-206/D System

D=DSP version of **MA-206** with independent amplification on each way and internal processing through DSP included. Transducers and waveguides are those explained in 2.2 and 2.3.

The **Class D** amplification modules are **1000 W** for the low way and **500 W** for the high way. Their high efficiency (almost 90%) allows their location on the lower panel without the necessity of forced cooling. We eliminate any fan or any other auxiliary device which may fail because of extra mechanical work.

The DSP control software allows:

- Parametric equalizations
- Delays
- Gain control for each way
- Crossovers up to 24 dB/Oct
- Limiters for each way

The adjustments can be done through a rear screen placed on each **MA-206/D** or through PC with RJ45 connectors.

2.5.1. Rear connections

Each unit of **MA-206/D** includes a Rear Panel with the following items:

A) **RJ45 INPUT** : PC Signal Input

B) **RJ45 LINK** : PC Link Signal

C) **INPUT SIGNAL** : Balanced XLR input signal connector
1= Shield 2= Live 3= Return

D) **LINK INPUT SIGNAL** : Balanced XLR connector for paralleling several units, which will share the same input.
1= Shield 2= Live 3= Return

E) **AC INPUT** : Input PowerCon connector.

F) **AC STACKING OUTPUT** : PowerCon Output connector to feed a secondary cabinet.

G) **AC MAINS LED INDICATORS**

- **ON**: Lights when AC input is correct.
- **STAND BY**: Lights during power-up sequence.
- **OVERVOLTAGE PROTECTION**: Lights if AC input voltage is over 250VAC.
The system protects itself and will not start up until AC level is correct.

H) **SIGNAL OUT** : Signal output to feed 3 passive units of **MA-206/P**.

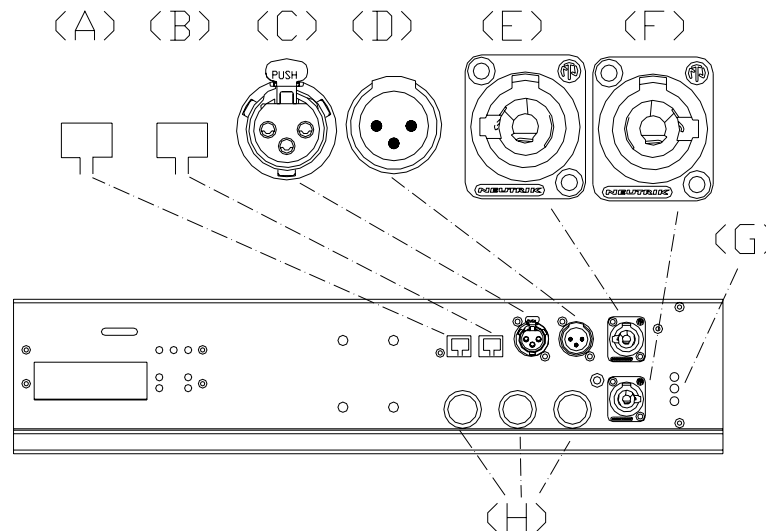

Fig.9. Connections panel for **MA-206/D**

2.6. MA-206/P

P=Passive version of **MA-206** feed by a **MA206/D**. Transducers and waveguides are those explained in 2.2 and 2.3.

2.6.1. Rear connections

Each unit of **MA-206/P** includes a Rear Panel with the following items:

A) **SPEAKON INPUT:** Input signal:

PIN +1 : Woofer + (Positive)

PIN -1 : Woofer - (Negative)

PIN +2: Driver + (Positive)

PIN -2: Driver - (Negative)

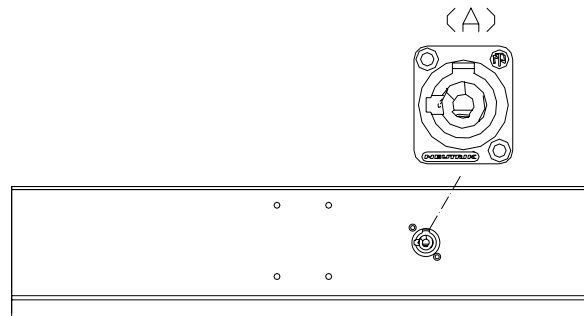

Fig.10. Connections panel for **MA-206/P**

3. MAW-115D SYSTEM DESCRIPTION

Active version with DSP control

This model is a Bass Reflex unit that contains one 15" Neodymium Woofer.

3.1. 15" Neodymium Loudspeakers

The 15" transducers used, which are probably the best ones on the current market with these features, offer a clean, undistorted low frequency reproduction at very high sound pressure levels. This low distortion and unmatched quality are further and significantly improved by the double demodulating rings (DDR) embedded in the pole piece of the magnetic structure. These are designed to dramatically reduce the intermodulation and third order distortion while also improving transient response. Excellent heat dissipation is achieved by incorporating external magnetic configuration.

3.2.Finish

The **MAW-115D** has been made of vibration and moisture-resistant birch plywood. All cutting and milling work, as well as drilling operations, has been developed by computerized numeric control machinery (CNC) which allows us to ensure perfect and accurate assembly.

The black finish, which uses totally ecological water-based acrylic resin paint, provides an excellent external protection

We also include a 1.5mm black-painted steel grille with acoustically transparent foam on the front side.

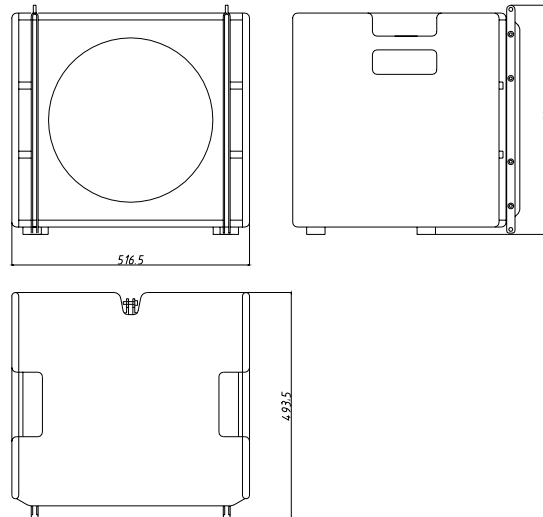

Fig.11. Dimensions of **MAW-115D**

Each unit incorporates rigging on its side for safe, easy and quick flying or stacking.

3.3. MAW-115D System

D=DSP version of **MAW-115** with in-built amplification and internal processing through DSP included.

The **Class D** amplification module is **1000 W**. Their high efficiency (almost 90%) allows their location on the rear panel without the necessity of forced cooling. We eliminate any fan or any other auxiliary device which may fail because of extra mechanical work.

The DSP control software allows:

- Parametric equalizations
- Delays
- Gain control
- Crossovers up to 24 dB/Oct
- Limiters

The adjustments can be done through a rear screen placed on each **MAW-115/D** or through PC with RJ45 connectors.

3.3.1.Rear connections

Each unit of **MAW-115/D** includes a Rear Aluminium Panel with the following items:

A) **RJ45 INPUT** : PC Signal Input

B) **RJ45 LINK** : PC Link Signal

C) **INPUT SIGNAL** : Balanced XLR input signal connector
1= Shield 2= Live 3= Return

D) **LINK INPUT SIGNAL:** Balanced XLR connector for paralleling several units, which will share the same input.

1= Shield 2= Live 3= Return

E) **AC INPUT :** Input PowerCon connector.

F) **AC STACKING OUTPUT:** PowerCon Output connector to feed a secondary cabinet.

G) **AC MAINS LED INDICATORS**

- **ON:** Lights when AC input is correct.
- **STAND BY:** Lights during power-up sequence.
- **OVERVOLTAGE PROTECTION:** Lights if AC input voltage is over 250VAC.

The system protects itself and will not start up until AC level is correct.

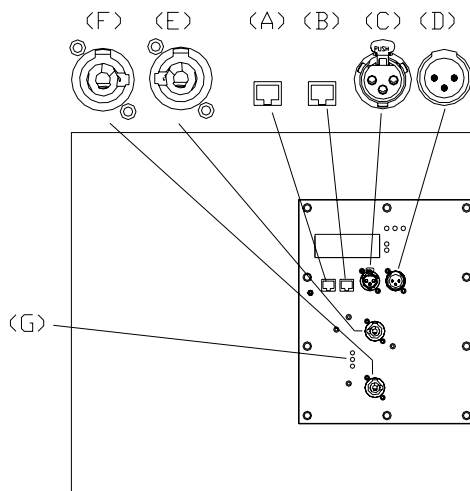

Fig.12. Connections panel for **MAW-115/D**

4. MAW-215/2K SYSTEM DESCRIPTION

MAW-215/D/2: Active version with DSP control

It includes two 15" Neodymium Woofers and they are acoustically controlled by the volume of their three chambers. Despite its compact size, we obtain an excellent performance with very low levels of distortion.

4.1. 15" Neodymium Loudspeakers

The 15" transducers used, which are probably the best ones on the current market with these features, offer a clean, undistorted low frequency reproduction at very high sound pressure levels. This low distortion and unmatched quality are further and significantly improved by the double demodulating rings (DDR) embedded in the pole piece of the magnetic structure. These are designed to dramatically reduce the intermodulation and third order distortion while also improving transient response. Excellent heat dissipation is achieved by incorporating external magnetic configuration.

4.2. Finish

The **MAW-215D/2K** has been made of vibration and moisture-resistant birch plywood. All cutting and milling work, as well as drilling operations, has been developed by computerized numeric control machinery (CNC) which allows us to ensure perfect and accurate assembly.

The black finish, which uses totally ecological water-based acrylic resin paint, provides an excellent external protection

We also include a 2mm black-painted steel grille with acoustically transparent foam on the front side.

Each unit incorporates rigging on its side for safe, easy and quick flying or stacking.

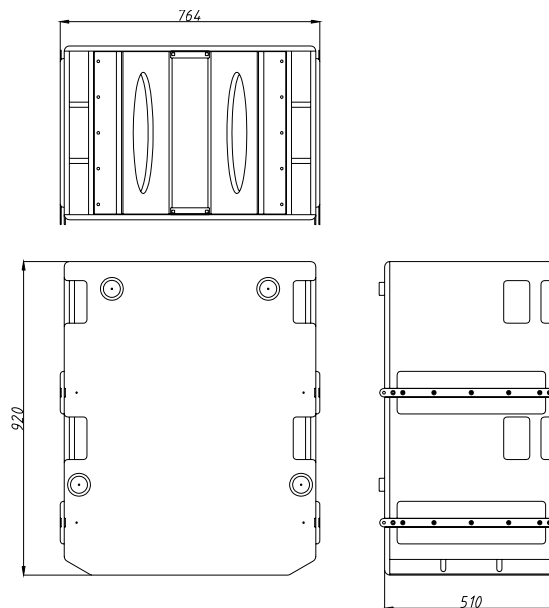

Fig.13. Dimensions of **MAW-215D/2K**

4.3. MAW-215/D/2K System

D=DSP version of **MAW-215** with in-built amplification and internal processing through DSP included.

The **Class D** amplification modules are 1000 W (two units, total **2000 W**). Their high efficiency (almost 90%) allows their location on the rear panel without the necessity of forced cooling. We eliminate any fan or any other auxiliary device which may fail because of extra mechanical work.

The DSP control software allows:

- Parametric equalizations
- Delays
- Gain control
- Crossovers up to 24 dB/Oct
- Limiters

The adjustments can be done through a rear screen placed on each **MAW-215/D/2K** or through PC with RJ45 connectors.

4.3.1.Rear connections

Each unit of **MAW-215/D** includes a 4mm Rear Panel with the following items:

A) **RJ45 INPUT** : PC Signal Input

B) **RJ45 LINK** : PC Link Signal

C) **INPUT SIGNAL** : Balanced XLR input signal connector
1= Shield 2= Live 3= Return

D) **LINK INPUT SIGNAL** : Balanced XLR connector for paralleling several units, which will share the same input.
1= Shield 2= Live 3= Return

E) **AC INPUT** : Input PowerCon connector.

F) **AC STACKING OUTPUT** : PowerCon Output connector to feed a secondary cabinet.

G) AC MAINS LED INDICATORS

- **ON**: Lights when AC input is correct.
- **STAND BY**: Lights during power-up sequence.
- **OVERVOLTAGE PROTECTION**: Lights if AC input voltage is over 250VAC.
The system protects itself and will not start up until AC level is correct.

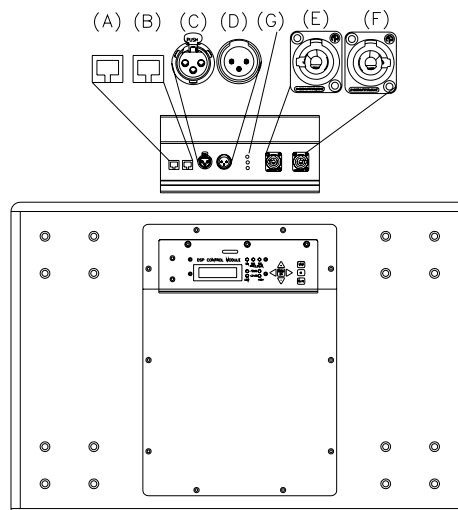

Fig.14. Connections panel for **MAW-215/D/2K**

5.-SYSTEM CONNECTIONS

As an example, let us start with an 8 **MA-206** cabinet configuration (including 2 units of **MA-206/D** and 6 units of **MA-206/P**). All the rest of configurations may be deduced from this base system.

Each set includes a **FACTORY PRESET** which can be modify through the control software or the in-built rear digital screen.

A sound system must be switched on sequentially. Firstly switch on the sound sources such as CD players. Then, the mixer and finally the self-powered cabinets. If you are using several units it is recommended that you switch them on sequentially one at time.

If you are not using **MA-206** in combination with low frequency reinforcement units, plug the output of mixer into the first unit of **MA-206/D** Input. (Fig.9. **INPUT SIGNAL (C)**).

Daisy chain the first unit of **MA-206/D** with the second unit of **MA-206/D** through **LINK INPUT SIGNAL** connectors.

Feed the first unit of **MA-206/D** through **AC INPUT** connector (Fig.9.(E)). and simply daisy chain the second unit of **MA-206/D** through **AC STACKING OUTPUT**.

Connect the 3 signal outputs from the **MA-206/D** (Fig.9.(H)) to the Speakon inputs of each **MA-206/P**.

For the DSP control via PC/Laptop simply connect the PC output to the **RJ45 INPUT** (Fig.9.(A)) of the first **MA206/D** unit and daisy chain the signal to the second of **MA206/D** unit through **RJ45 LINK** (Fig.9.(B)).

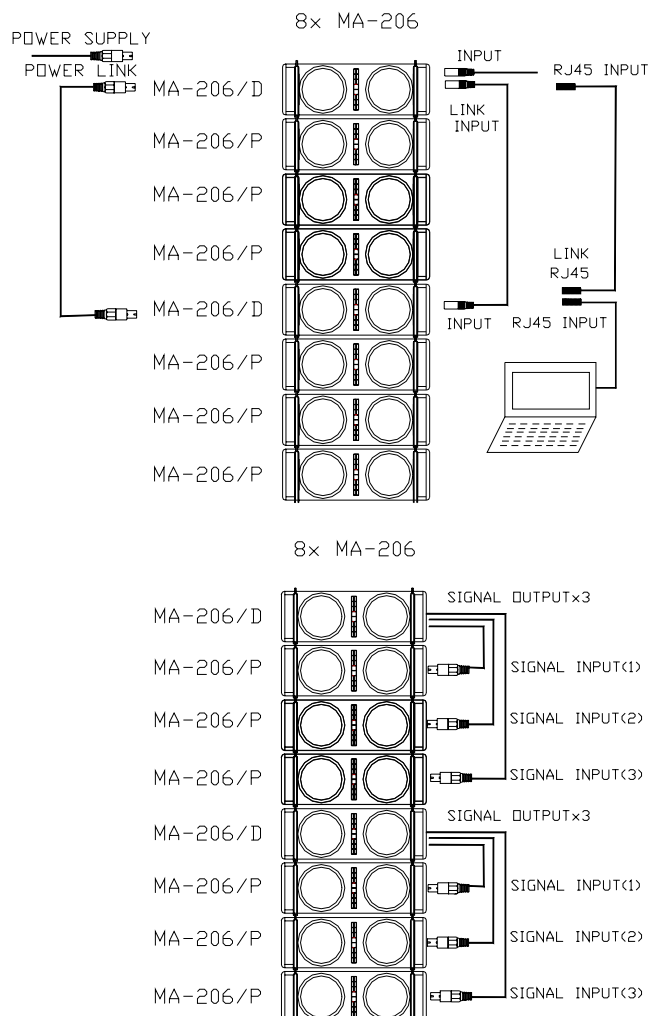

Fig.15. 8 x MA-206 Connections

6. FLYING SYSTEM

Flying an **MA** system is easy, fast and secure. To perform any operations related to flying the system, read the present document, and act on the warnings and advice given.

Only experienced installers with adequate knowledge of the system and local safety regulations should fly speaker cabinets.

It is the user's responsibility to ensure that the systems to be flown and the flying accessories (such as chains, eyebolts, lock pins...) comply with state and local regulations. They should be regularly inspected and replaced if in doubt.

When flying enclosures from ceiling support structures, extreme care should be taken to assure the load bearing capabilities of the structures. Do not fly systems from unsafe structures.

All flying accessories that are not supplied by **Amate Electroacústica** are the user's responsibility. Use at your own risk.

Remember that no risks should be taken with regards to public safety.

6.1.Description

Each **MA-206** cabinet includes flying structures on the front-lateral sides and on the back side. These structures are manufactured from stainless steel; they are affixed with special crop resistant screws. The front structures are used to vertically join the cabinets; the back structures are used to vertically join the cabinets and to tilt them.

Angles can be changed from 0° to 8°. To safely lock the guides, the lock pins supplied must be used.

To tilt the cabinets, the back structures and the back guide must be used.

The available degrees are 0°, 1°, 2°, 3°, 4°, 5°, 6°, 7° and 8°.

To fix the guides to the holes, highly resistant 8mm pins are used with ball safety lock.

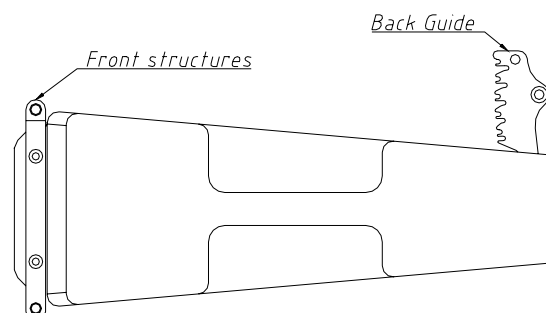

Fig.16. Flying structures (general view)

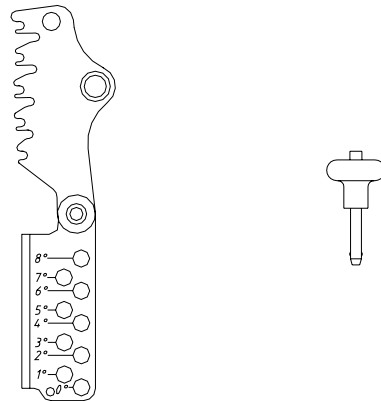

Fig.17. Back guide with graduation and Ball Lock Pins

The flying Frame is made from stainless-steel and is designed to handle great loads. It includes a centre and lateral bars to reinforce the whole structure. The centre bar has a series of holes that provide a pickup point for the steel chain slings or the hoists. The pickup point chosen will determine the tilt angle of the whole array system.

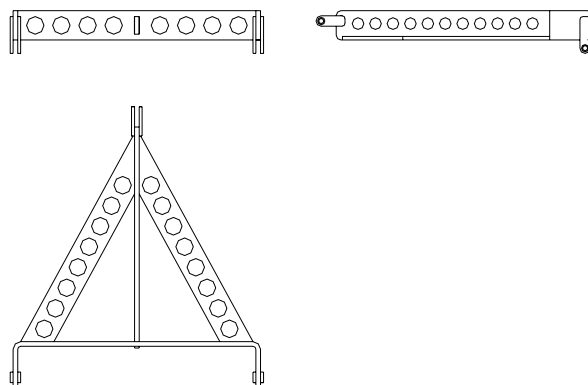

Fig.18. Flying Bumper

A shackle is included on the Flying Bumper Kit. It can be fitted into any of the centre bar holes (depending on the gravity centre of the configuration). The shackle can be also hung on the elevation motor of the system.

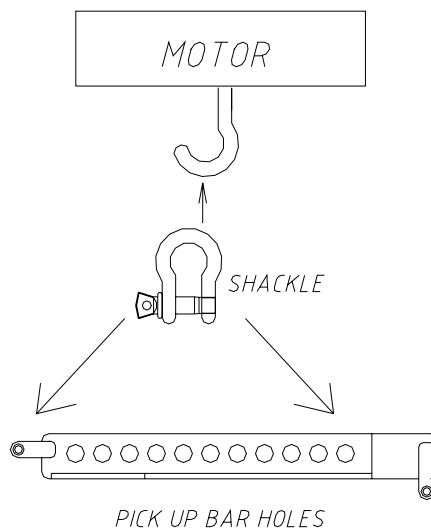

Fig.19. Flying structure

We **recommend** the use of a safety cable on the shackles' hole. (see Fig.23). You should coil the cable around the shackle to avoid any incident in case of unscrewed guides.

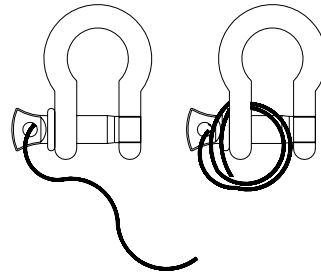

Fig.20. Safety cable for shackle

6.2. MA-206 Flying

Use the back guide to choose the desired tilt angle (0° , 1° , 2° , 3° , 4° , 5° , 6° , 7° , 8°). Set the back guide between the back structures of the cabinet that are placed above. Lock the guides with the safety pins.

When you are flying the first cabinet, follow the previous explanation but set the back guide between the back structures of the Bumper.

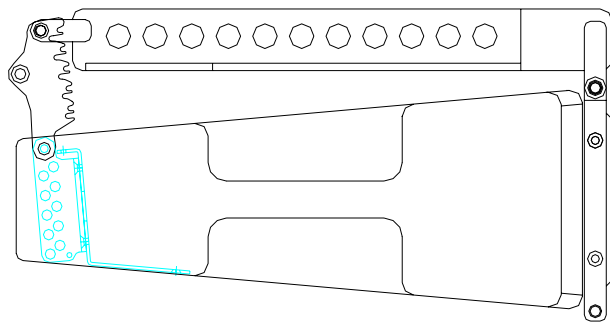

Fig.21. MA-206 Flying with Bumper

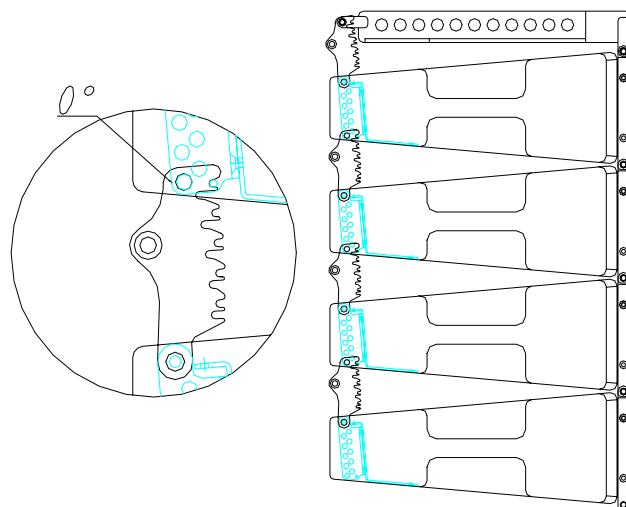

Fig.22. MA-206 Flying. Flat Line Array
 0° (Back Guide = 0°)

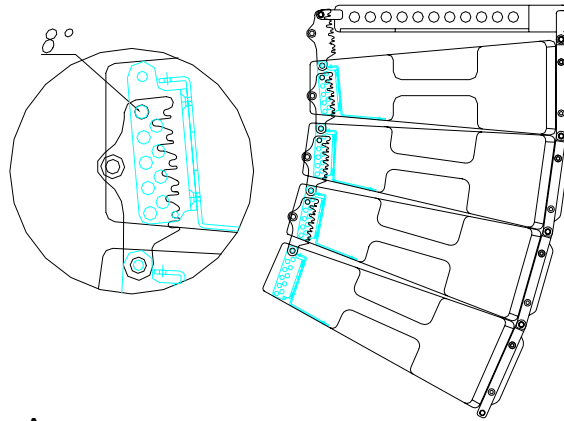

Fig.23. MA-206 Flying. Curved Line Array.
8° (Back Guide =8°)

7- OVERVOLTAGE PROTECTION

The MA206D, MAW115D and MAW215D/2K models include over voltage protection.

An electronic circuit compares the input voltage with a reference value on the AC Input connector (MAINS). When the input voltage is higher than 250 Volts the circuit starts to work, blocking the input voltage until its value returns to its correct limits (230V +/- 10%).

When the Overvoltage LED lights (in RED) (Fig.9. **LED OVERVOLTAGE (G)**, Fig.12. **LED OVERVOLTAGE (G)**, Fig.14. **LED OVERVOLTAGE (G)**), the cabinet stops working (or works intermittently) until the correct voltage values are reached again.

8. TECHNICAL SHEETS

MA-206

Line Input (Balanced)

1.8 V

Impedance

10k ohms

Mains

230V +/- 10%. Overvoltage protection.

Consumption at Maximum Power

6 A

Frequency Response

LF Usable bandwidth	105Hz - 1k9Hz (-10 dB)	(1W, processed)
HF Usable bandwidth	1k9Hz - 18kHz (-10 dB)	(1W, processed)
Total Usable bandwidth	105Hz - 18kHz (-10 dB)	(1W, processed)

Sensitivity MA206P

LF (4V rms @ 1m)	99 dB SPL
HF (4V rms @ 1m)	105 dB SPL
Total SPL (4V rms @ 1m)	99 dB SPL

Amplifier Power MA206D

LF	1000 W
HF	500 W

Nominal Directivity (-6dB)

Horizontal	symmetrical 90°
Vertical	defined by the array

System Output

(Long Term)
One enclosure
Two enclosures
Four enclosures

Continuous SPL

(flat array)
123 dB
129 dB
135 dB

Components

LF	2x6.5" Neodymium Woofer (1.5" voice coil)
HF	1x1" Neodymium Pure Titanium compression Driver (1" ³ / ₄ voice coil) mounted on property waveguide

Enclosure

Width	516.5 mm
Height	198 mm
Depth	493.5mm
Trap angle	2 x 5°
Weight (net)	17 Kg (MA206D) /13Kg (MA206P)
Connectors	
MA206D	2x AC PowerCon (Input, Link) 2x XLR (Input, Link) 2x RJ45 for External PC Control
MA206P	1x SPEAKON +1,-1 LOW / +2,-2 HIGH

Material	Birch plywood, Stainless Steel Flying Hardware, Black painted Steel Grille
Finish	Black (Acrylic resin, ecological water-based)
Rigging	Integrated flying hardware and handles

MAW-115/D

Line Input (Balanced)

1.8 V

Impedance

10k ohms

Mains

230V +/- 10% Overvoltage protection

Consumption at Maximum Power

5 A

Frequency Response

LF Usable bandwidth 38 Hz - 150 Hz (-10 dB) (1W, processed)

Sensitivity

LF (1W rms @ 1m) 97 dB SPL

Amplifier Power

LF 1000 W

Nominal Directivity (-6dB)

Horizontal omnidirectional

Vertical omnidirectional

System Output

(Long Term)

One enclosure

Two enclosure

Four enclosure

Continuous SPL

(flat array)

127 dB

133 dB

139 dB

Components

LF 1x15" Long excursion Neodymium Woofer (100mm Voice Coil)

Enclosure

Width 516.5mm

Height 498 mm

Depth 493.5 mm

Weight (net) 30 Kg

Connectors 1x AC INPUT PowerCon
1x AC STACKINGOUTPUT PowerCon
1x INPUT XLR Balanced
1x LINK XLR Balanced
2x RJ45 for External PC Control

Material Birch plywood, Stainless Steel Flying Hardware, Black Painted Steel grille

Finish Black (Acrylic resin, ecological water-based)

Rigging Integrated flying hardware and handles

MAW-215/D/2K

Line Input (Balanced)

1.8 V

Impedance

10k ohms

Mains

230V +/- 10% Overvoltage Protection

Consumption at Maximum Power

9 A

Frequency Response

LF Usable bandwidth 32 Hz - 140 Hz (-10 dB) (1W, processed)

Sensitivity

LF (2V rms @ 1m) 102 dB SPL

Amplifier Power

LF 2000 W

Nominal Directivity (-6dB)

Horizontal omnidirectional

Vertical omnidirectional

System Output

(Long Term)

One enclosure @ 2000 W

Two enclosures @ 2000 W

Four enclosures @ 2000 W

Continuous SPL

(flat array)

135 dB

141 dB

147 dB

Components

LF 2x15" Long excursion Neodymium Woofer (100mm Voice Coil)

Enclosure

Width 740 mm

Height 510 mm

Depth 920 mm

Weight (net) 72 Kg

Connectors 1x AC INPUT PowerCon
1x AC STACKINGOUTPUT PowerCon
1x INPUT XLR Balanced
1x LINK XLR Balanced
2x RJ45 for External PC Control

Material Birch plywood, Stainless Steel Flying Hardware, 2mm Black Painted steel grille

Finish Black (Acrylic resin, ecological water-based)

Rigging Integrated flying hardware and handles

9.TROUBLESHOOTING

No Power

- Make sure that the cabinet is plugged in.
- The Fuse is blown. Replace the fuse on fuse holder with one of the same type. This replacement must be done by specialized people as the fuse is set inside the amplification modules. AC Voltage may be controlled by rotating the Fuse 90° (230V or 115V). **See fuse holder for more information.**

No Sound

- Check that the mixer, sound source and processor is sending signal to the unit.
- Check that the cable from the mixer, sound source or processor to the units is correctly connected. Replace the cable if defective.
- Make sure the output volume (gain) control on the mixing console and processor is sufficiently turned up to drive the inputs of the speakers.
- Make sure the mixer and the processor do not have a Mute on.

Distorted sound

- The system is overloaded and has reached maximum power. Turn down the mixer's output or the channel's gain.

Poor bass performance

- Check the polarity of the connections between the mixer/processor and the **MA-206** amplifiers. If you have inverted any of the Pins (1,2 or 3) in one of the extremes of the wire, the losses may be extremely high.

Noise and Hum

- Make sure all connections to the active units are in good conditions.
- Avoid routing the signal cables near AC cables, power transformers, or EMI-inducing devices.
- Check if there is any light dimmer on the same AC circuit as the cabinet. Connect the sound system to a different phase than the lights.

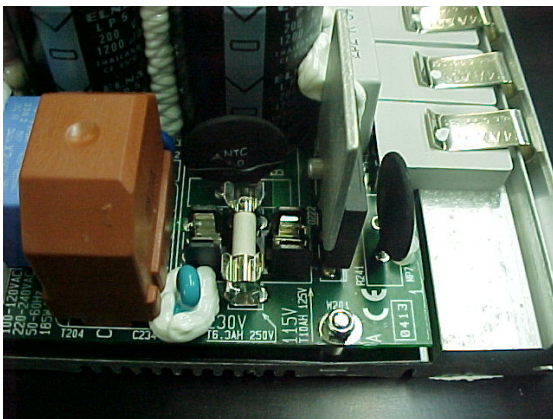

Fig.25. Fuse position (front view)



VERTICAL: 220V



HORIZONTAL: 115V

Overvoltage LED (on RED)

- Check that the input voltage is within the right values (230V +/- 10%)

10. MA206 FLYING

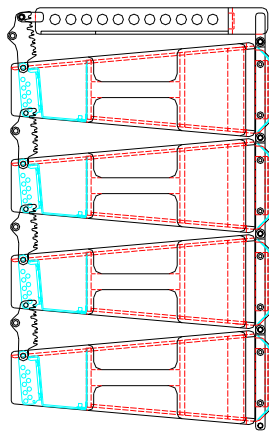

TA-206

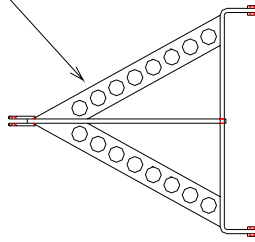

MA206
You need
TA-206 Bumper

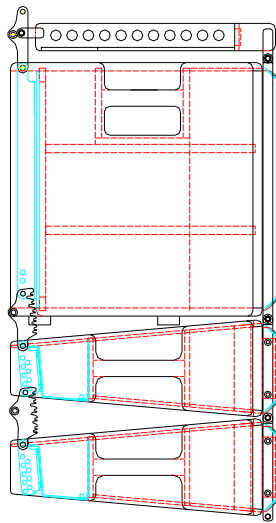

TA-206

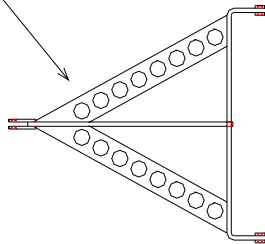

MA206 + MAW115
You need
TA-206 Bumper

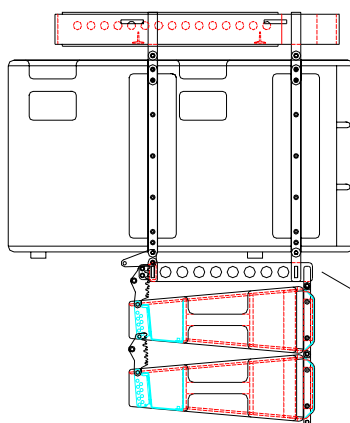

TA-210HD

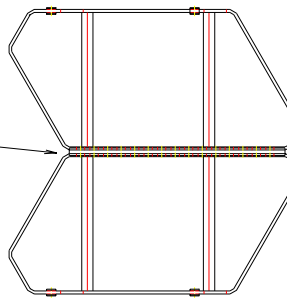

MA206 + MAW215
You need
TA-210HD Bumper
FA-10/6 Frame Adaptor
4 x BL-8 Ball Lock Pins

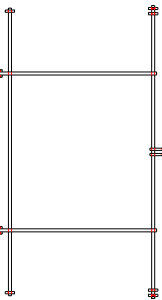

FA-10/6

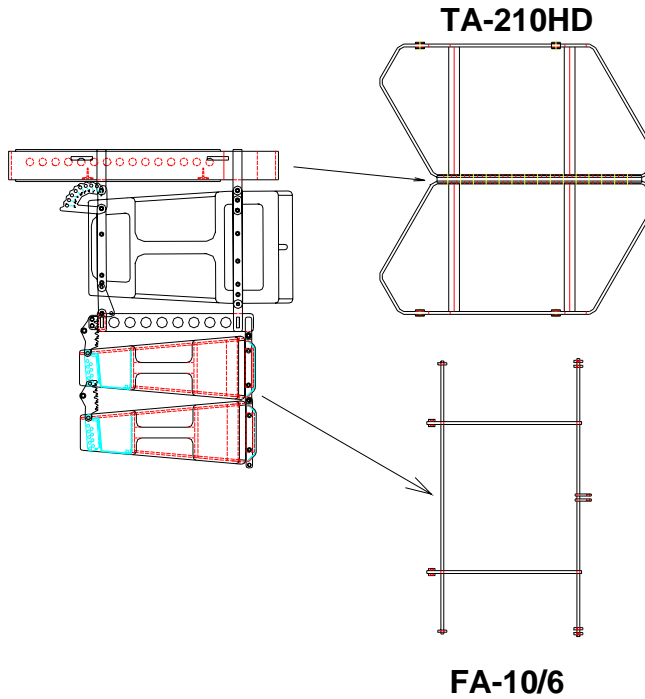

MA206 + MA210
You need
TA-210HD Bumper
FA-10/6 Frame Adaptor
4 x BL-8 Ball Lock Pins

11. MA206 STACKING

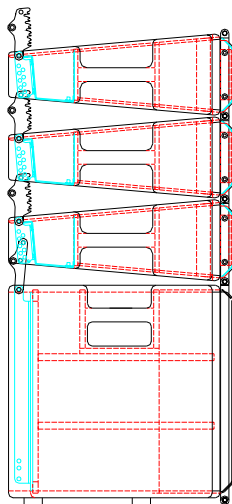

MA206 + MAW115

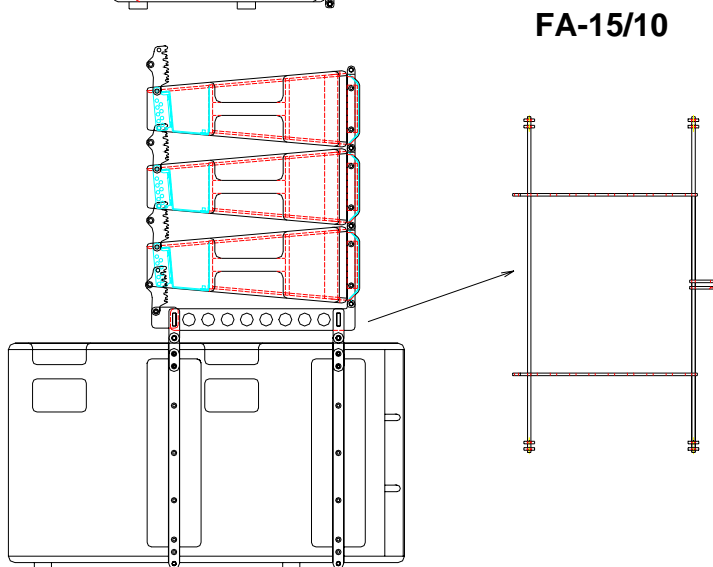

MA206 + MAW215
You need
FA-15/6 Frame Adaptor
4 x BL-8 Ball Lock Pins for sub